



IN THE HIGH COURT OF JUDICATURE AT BOMBAY
ORDINARY ORIGINAL CIVIL JURISDICTION
IN ITS COMMERCIAL DIVISION

INTERIM APPLICATION (L) NO.13706 OF 2024
IN
COMMERCIAL IP SUIT (L) NO.13638 OF 2024

Pidilite Industries Limited ...Applicant /Plaintiff
Versus

Astral Limited (Formerly known as
Resinova Chemie Limited) ...Respondents/Defendant

Mr. Virag Tulzapurkar, Sr. Advocate, a/w. Mr.Hiren Kamod a/w. Mr. Nishad Nadkarni, Mr. Aasif Navodia, Ms. Khushboo Jhunjhunwala, Ms. Rakshita Singh, and Ms. Jaanvi Chopra, i/b. Khaitan & Co.for the Applicant/Plaintiff.

Mr. Ashish Kamat, Sr. Adv. a/w. Mr. Rashmin Khandekar a/w. Mr. C. A Brijesh, Mr. Aditya Mahadevia, Mr. Krishna Gambhir,Mr. Karan Khiani i/b. Rashmi Singh & Karan Khiani for the Respondent/Defendant.

CORAM : FIRDOSH P. POONIWALLA, J. J.

RESERVED ON : 9th MAY 2024

PRONOUNCED ON : 13th JUNE 2024

P.C.:

1. The Plaintiff was incorporated in 1969 and has been carrying on business in the field of construction bonding chemicals/ materials, additives products including sealants, adhesives, automotive chemicals, art materials, industrial and textile resins and organic

pigments and preparations and other products including waterproofing chemicals, construction and paint chemicals.

2. The Plaintiff offers a wide range of sealants and adhesives under its PV SEAL brand which are in the nature of a pipe glue and a chemical compound/adhesive used for joining/fusing various kinds of plastic pipes. The Plaintiff uses distinctive labels upon and in relation to its M-SEAL PV SEAL products.

3. Since 2015, the Plaintiff's M-SEAL PV SEAL products bearing distinctive PV SEAL labels are sold openly extensively, continuously and in an uninterrupted manner in a distinctive tin container having unique and distinctive shape, size, contours and configurations.

4. In or about 2018, the Plaintiff transitioned from tin containers to Coex plastic containers for its aforementioned solvent cement products being sold under mark M-SEAL PV SEAL. The Plaintiff was the first in the industry to make this transition to Coex plastic containers and accordingly designed containers for the M-SEAL PV SEAL products that could be applied to different variants.

5. The same were introduced and have been in the market since 2019 and the tin containers were slowly being phased out over time. From 2023, only the Coex plastic containers are being used.

6. In or about 2024, the Plaintiff came across a range of solvent cement products manufactured and/or marketed and/or sold by the Defendant under the brand/mark SOLVOBOND, being sold in containers which, according to the Plaintiff, are an imitation and are deceptively similar to the distinctive M-SEAL PV SEAL container of the Plaintiff, including identical shape, configuration, caps including vertical lines and extended ridges thereon and multiple grooves below the cap connecting to the seal of the container.

7. In these circumstances, the Plaintiff filed the present Suit alleging that the Defendant is engaged in infringement of its design, copyright and committing the tort of passing of the goods of the Defendant as the goods of the Plaintiff. It is the case of the Plaintiff that the Defendant is systematically and blatantly imitating the Plaintiff's brand /product and/or trying to come as close as possible and/or surreptitiously trying to hijack the Plaintiff's containers and are misleading/deceiving public at large. Therefore, the Plaintiff has filed the present Interim Application.

8. Mr. Tulzapurkar, the learned Senior Counsel appearing on behalf of the Plaintiff in support of the Interim Application, submitted that the Plaintiff was claiming originality and novelty in the shape and configuration of its distinctive M-SEAL PV SEAL container. The

Controller of Design had granted a Certificate of Registration to the Plaintiff as proprietor of the registered design. He submitted that, by virtue of the provisions of Section 10(4) of the Designs Act, 2000 (“the Designs Act”) the register of designs is prima facie evidence of any matter which by the Designs Act has been directed or authorised to be entered therein. He submitted that the Plaintiff’s design, when considered as a whole, is distinctive and unique and has an appeal to the eye. The novelty of the Plaintiff’s design resides in the shape and configuration thereof.

9. Mr. Tulzapurkar referred to Section 2(d) of the Designs Act and submitted that the Plaintiffs’ design satisfies all the requirements of the definition of a design and more so a registrable design. He submitted that designs under the Designs Act do not require any artistic element or virtue. The only criteria is “appeal to the eye”. He further submitted that ocular appeal is the definitive test of a valid design. What may appeal to one may appear bizarre to another. The corollary would therefore be that the Court while examining the ocular appeal of a design should not apply its own subjective standards. In this context he referred to a decision of the Delhi High Court in **TTK Prestige Limited vs. KCM Appliances Private Limited**¹.

1 2023 SCC Online Del 2129

10. Further he submitted that it is well settled that the test to consider the novelty of a design is whether the same appeals to the eye as a whole and, in this context, referred to a decision of this Court in **Kemp & Co. vs. Prima Plastics Limited**².

11. Next, Mr. Tulzapurkar submitted that the Plaintiff's distinctive M-SEAL PV SEAL container is new and original and has not been published /disclosed to the public in India or anywhere in the world in a tangible form prior to the filing date by the Plaintiff itself or others. He submitted that the Plaintiff's design is novel and original and hence it is validly registered. He referred to the definition of the term "original" under Section 2(g) of the Designs Act. He submitted that the Defendant's contention that the Plaintiffs' distinctive M-SEAL PV SEAL container design is not original is misplaced. He submitted that the Plaintiff is the first in the market to use the distinctive M-SEAL PV SEAL container design on such a plastic container for solvent cement products and the same has been identified by the consumers for its unique shape and configuration. He submitted that the Plaintiff's distinctive M-SEAL PV SEAL design certainly falls within the meaning of "original" as defined in Section 2(g) of the Act.

² 1998 SCC Online Bom 437.

12. Mr. Tulzapurkar further submitted that the defense of prior publication raised by the Defendant under Section 19(1) (a) and 19(1) (b) of the Designs Act is contrary to settled law. The provisions of 19(1) (a) apply only when the design of the Plaintiff as is stands registered by someone else in India prior to the Plaintiff. Section 19(1) (a) does not apply if the Plaintiff's design is registered by anyone else outside India. He submitted that none of the alleged prior art produced by the Defendant in its reply for registered designs in India is anywhere close to or similar to Plaintiff's distinctive M-SEAL PV SEAL container.

13. Mr. Tulzapurkar further submitted that the provisions of Section 19(1)(b) of the Designs Act apply only when the suit design has been published in India or in any other country prior to the date of registration. The prior publication has therefore to be of the design of the Plaintiff itself and no other design. Similar designs do not fall within the ambit of Section 19(1)(b). Prior publication even of a deceptively or confusing similar design cannot invite the applicability of Section 19(1)(b) of the Designs Act. In this context, he referred a decision of the Delhi High Court in **Sirona Hygiene Private Limited Vs. Amazon Seller Services Pvt. Ltd**³.

³[CS (Comm) 503/2022].

14. Mr. Tulzapurkar further submitted that while it is correct that under Section 19(1) (c) of the Designs Act even a prior similar design can be considered, in so far as the present case is concerned, Section 19(1)(c) cannot be pressed into action since there is no material on record to show that there was anybody with the design or even a substantially similar design (when taken as a whole) either in India or elsewhere, of the kind over which the Plaintiffs claim proprietary rights. Mr. Tulzapurkar submitted that none of the design registrations or prior representations or containers produced by the Defendant are identical or similar to the Plaintiffs' container.

15. Mr. Tulzapurkar further submitted that while comparing the designs of containers it is not permissible to break down an article into parts/element/integers and to compare individual parts with parts of the suit container. The article must be viewed as a whole. Mosaicing (i.e., breaking down into pieces from different articles and comparing them with the suit design) is not permissible. Mr. Tulzapurkar submitted that the Defendant has sought to dissect the Plaintiff's distinctive M-SEAL PV SEAL container into parts and has sought to compare individual elements/features of the Plaintiff's containers with other designs, patents and products, which is not permissible. The Plaintiff's design has to be looked at as a whole and cannot be

segregated/dissected into separate integers. The test of “appeal to the eye” has to be considered for the design as a whole. In this context he referred to the judgement of this court in **Cello vs. Modware India**⁴.

16. Mr. Tulzapurkar further submitted that the filing of the Plaintiffs’ Patent Application prior to the Plaintiff’s Design Application is of no consequence and does not constitute prior publication. The Patent Application was made on 28th September 2018. The Design Application was made on 5th October 2018. The Patent Application was published only on 3rd April 2020 much after the Design Application was made. As on date of the Design Application, the Patent Application was confidential and not published.

17. Mr. Tulzapurkar next submitted that the Plaintiffs’ container’s design is not a mere trade variant. He submitted that the Defendant had failed to demonstrate that there was any prior design or any similar design that preceded the Plaintiff’s design and that the Plaintiff has merely created a trade variant. Mr. Tulzapurkar made detailed submissions in this regard and referred to the decisions of this Court in (i) **Selvel Industries and Anr. v. Om Plast (India)**⁵, (ii) **Frito-Lay**

4 2017 SCC Online Bom 394

5 2016 SCC Online Bom 6945

North America Inc. vs. Balaji Wafers Pvt. Ltd.⁶, (iii) **Cello** (surpa) (iv) **Whirlpool of India Ltd. V. Videocon Industries Ltd**⁷.

18. Mr. Tulzapurkar submitted that the Defendant's impugned container was an obvious imitation of the Plaintiff's container design and constitutes infringement of the said design. During the hearing the Defendant did not even contend that the Defendant's impugned design was not similar or was different from the Plaintiff's suit design. In this context Mr. Tulzapurkar submitted that the Defendant had not given any plausible explanation as to how it chanced upon/adopted the impugned design for its container. He submitted that, in the absence of plausible explanation as to how the Defendants chanced upon the design used on the impugned container, and given the identity/similarity between the rival designs, an order of injunction must follow. He submitted that in fact the Defendant had two separate design registrations of its own as depicted at Exhibit O to the Plaint and Exhibit L to the Affidavit in Reply. However, the Defendant had copied the Plaintiff's registered design having despite design registrations of its own.

6 2020 SCC Online Bom 2375

7 2014 SCC Online Bom 565

19. For these reasons, Mr. Tulzapurkar submitted that the Plaintiff was entitled to the ad-interim reliefs sought by it.

20. The Defendant has raised various defences to oppose the grant of ad-interim reliefs. However, it is important to note that it is not the defence of the Defendant that its container is not almost identical to the Plaintiff's container. Further, a comparison of the containers of the Plaintiff and the Defendant at page 34 of the Plaint show that they are almost identical to each other. The parties have also given to the Court the said two containers physically. On an examination of the said containers, I find that the Defendant's container is almost identical to that of the Plaintiff. In these circumstances, there is no dispute that the Defendant's container is almost identical to that of the Plaintiff, and, therefore, I will have to consider the other defences raised by the Defendant in order to consider whether the Plaintiff is entitled to ad interim reliefs.

21. The first defence taken by the Defendant is that the suit design is disentitled from protection under Section 19(1)(e) of the Designs Act because it is not a design as defined under Section 2(d) as it does not appeal to the eye. In this context, Mr. Kamat submitted that there is nothing in the Plaintiff's container that "appeals to the eye", which is

a sine qua non for it to qualify as an enforceable design under Section 2(d) of the Designs Act.

22. In this context Mr. Kamat referred to the decision of the Delhi High Court in **Jayson Industries and Anr. Vs. Crown Craft (India) Pvt. Ltd** (IA 13422 of 2022 and 13425/2022 in CS (COMM) 580/2022). He submitted that the article in question must be unique or novel or original in regard to the elements such as shape, configuration, pattern, ornament and should have a visual aesthetic appeal. He submitted that a visual aesthetic appeal is not to be confused with artistic appeal. He submitted that the point is that there should be something “catchy” or “capricious” about the design in question. Basically, the design must not be “commonplace” or such which does not evoke any visual appeal whatsoever.

23. Mr. Kamat submitted that, in the present case, as far as the Plaintiff's design as applied to the container is concerned, there is nothing novel or original or appealing to the eye in any manner whatsoever. As far as the container of the Plaintiff is concerned, both the registered design and the container to which the design are applied are absolutely commonplace and have nothing unusual or capricious or catchy about them. There is no visual appeal and therefore it is

clearly an unenforceable design. In this context, Mr. Kamat referred to the Order of the Patents Appeal Tribunal in **In the matter of an Application for the Registration of a Design by Associated Colour Printers Ltd. (No.814, 271)**⁸.

24. Further, Mr. Kamat submitted that the registration of the suit design, which is found at Exhibit-C to the Plaint, contains nothing more than a bare statement/claim that “the novelty resides in the shape and configuration of the “CONTAINER” as illustrated”.

25. Mr. Kamat further submitted that, in any event, the Plaint itself fails to make out even a prima facie case in terms of Section 2(d). The Plaint contains bare self-serving claims that the suit design and the features thereof are novel, unique, original, aesthetic and appealing without any substantiation or particulars.

26. He submitted that vague references are made to edges, shoulders, contours, shape and configuration of the suit design as applied to the container without even the barest minimal pleading to indicate what is either unique or appealing about such features vis a vis prior art.

8 Vol. LIV. Reports of Patent, Design, and Trade Mark Cases 203

27. Mr. Kamat submitted that, even in the case of **Selvel Industries** (supra) relied upon by the Plaintiff, the Court proceeded to test the rival designs only after first recording satisfaction with detailed particulars that the design in question was unique/ appealing to the eye, thereby answering in detail the peremptory question as to whether it was visually appealing or not.

28. Mr. Kamat submitted that the Plaintiff had attempted to contend that the Defendant had also applied for a design registration where it has sought protection in generally its shape and configuration. He submitted that the same can never be a fact in support of the Plaintiff's case. That is because it is the Plaintiff who seeks to enforce its registered design and therefore the Plaintiff is required to stand or fall on the strength of its own design. He submitted that an argument along these lines had been considered and rejected by this Court in **Atomberg Technologies Private Limited v. Luker Electric Technologies Private Limited**⁹.

29. In order to consider this defence it would be necessary to refer to Section 2(d) of the Designs Act, which defines a design, and reads as under:-

9 2023 SCC Online Bom 1151

“Section 2(d)

(d)“design” means only the features of shape, configuration, pattern, ornament or composition of lines or colours applied to any article whether in two dimensional or three dimensional or in both forms, by any industrial process or means, whether manual, mechanical or chemical, separate or combined, which in the finished article appeal to and are judged solely by the eye; but does not include any mode or principle of construction or anything which is in substance a mere mechanical device, and does not include any trade mark as defined in clause (v) of sub-section (1) of section 2 of the Trade and Merchandise Marks Act, 1958 (43 of 1958) or property mark as defined in section 479 of the Indian Penal Code (45 of 1860) or any artistic work as defined in clause (c) of section 2 of the Copyright Act, 1957 (14 of 1957);”

30. One of the ingredients of Section 2(d) is that the design must appeal to the eye. The question is what is the meaning of the words “appeal to the eye”.

31. In this context, paragraph 134 (ii) of the decision of the Delhi High Court in **TTK Prestige Limited** (supra) reads as under:-

“(ii) While ocular appeal is the definitive test of a valid design, what may appeal to one may appear bizarre to another. The corollary would, therefore, be that the Court, while examining the ocular appeal of a design, should not apply its own subjective standards.”

32. In this context, it would also be pertinent to refer to paragraph 8 of the decision of this Court in **Kemp & Co.B** (supra), which reads as under:-

“8. The first thing the plaintiffs are required to show is that the design of the defendants chair is the same and in any case substantially similar to the registered design of the 1st plaintiff.

Overall similarity in chairs of the plaintiffs and the defendants has to be determined by eye. If visual features of shape, configuration pattern of two designs are similar or strikingly similar by the eye, it is not necessary that it must be exactly identical and same. The matter must be looked at as one of substance and essential features of design ought to be considered. In (*Dunlop Rubber Co. v. Golf Ball Development*), 1931 (48) R.P.C. page 268, Farwell, J., observed, "Now, if a case where the registered design is made up of a pattern which has no one striking feature in it, but it appeals to the eye as a whole, it may very well be that another design may be an imitation of it which makes the same appeal to the eye, notwithstanding that there are many differences in the details. It may well be that is so; but I think conversely it is true to say that, if a design has in it a striking feature which captures and holds the eye, and which is the one thing that strikes the eye when one looks at the design, a design which otherwise may be like a registered design but which eliminates the striking feature or alters it so that it is not recognisable, in such a case it seems to me it is impossible to say that one is an imitation of the other, "The striking feature here in the present case is in the shape and pattern of chair consisting of holes of human face backrest and inserts, in the said holes. If the design of the chairs of the defendants is seen, to the eye of the Court, it clearly appears that it has the holes of human face backrest and removable inserts of the said holes. It is true that the seat of the chair of the registered design of the 1st plaintiff is not exactly identical and is rather different from the seat of the chair of the defendants, yet the said distinction does not make out a substantial difference in the light of the particular holes of human face backrest and removable inserts of the said holes which are conspicuous by their presence in the chair. The distinctive features of the plaintiffs chair are identical and similar to the chair of the defendants. If the plaintiffs and the defendants chairs are looked at in the light of the backrest, to the eye it appears to be the same and the difference of the design in seat pales into insignificance. The broad difference pointed out by the defendants in the design is of the seat which in the background of the striking and distinctive design of the backrest with holes of human face and removable inserts of the said holes do not seem to be of substance. Looking to the chairs of the plaintiffs and the defendants as a whole which have been shown in exhibits and were also shown to the Court during the course of hearing, I find that the design of the defendants chair is not substantially different from the plaintiffs chair. To that extent the case set out by the defendants in their affidavit-in-reply that the defendants design is substantially different from the plaintiffs registered design cannot be accepted. The defendants are not right when they say that their chairs are completely different from the chairs which are sold by the plaintiffs under the trade mark "Modema Champ" or that the defendants chairs are substantially different for the plaintiffs registered design."

33. As per these judgements, the design must appeal to the eye as a whole. While ocular appeal is the definitive test of a valid design, what may appeal to one may appear bizarre to the other. Therefore, the Court, while examining the ocular appeal of a design should not apply its own subjective standards. In other words, an objective test is to be applied.

34. Keeping in mind these principles, in my view, the design of the container of the Plaintiff does appeal to the eye. The Plaintiff's design when considered as a whole is distinctive and unique and has an appeal to the eye. The cap contains a unique pattern of vertical lines and elongated ridges around the outer surface and multiples grooves below the cap connecting to the seal. The container has a distinctive unique ring. The edge of the bottle has a unique design. There are unique edges at the shoulder and bottom of the container. All these ingredients taken together do appeal to the eye.

35. In my view, Mr. Tulzapurkar is also right in submitting that, if the registered design of various parties in respect of the containers referred to by the Defendant and the two registered designs of the Defendant in respect of a jar have appeal to the eyes, and are not commonplace, then the design of the Plaintiff also definitely has an appeal to the eye.

36. Therefore, for all these reasons, I am unable to accept the submission of the Defendant that the Plaintiff's design does not appeal to the eye and therefore is not a design as defined under Section 2(d) of the Designs Act.

37. The next defence relied upon by Mr. Kamat is that the suit design is disentitled from protection under Section 19(1)(b) of the Designs Act because it has been published in India or in any other country prior to the date of registration.

38. In this context, Mr. Kamat submitted that the Application for registration of the suit design was admittedly made on 5th October 2018. He submitted that, even within the short possible time available to it, the Defendant had been able to draw out prior art from the market which clearly indicated that there was nothing unique/appealing in the suit design viz a viz such prior art as would qualify as a design under Section 2(d) of the Act. In this context he referred to Exhibit-E of the Affidavit in Reply of the Defendant and the two Compilations of Documents referred to by the Defendant.





39. Mr. Kamat referred to the relevant material from the two compilations along with relevant dates as set out herein below:-

Compilation of Documents – 1:

Designs/ Products	Earliest Date of use
	<p>At least since June 23, 2015</p>
	<p>At least since October 30, 2017</p>

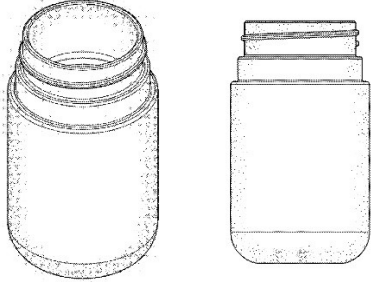
Compilation of Documents – 2:

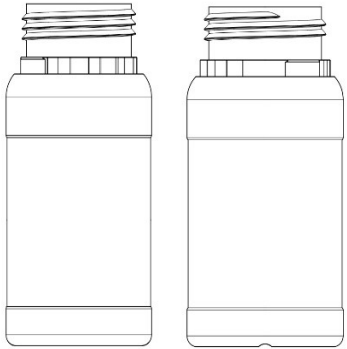
S.No	Registration No.	Date of Registration	Representations
	<p style="text-align: center;">/ Country</p>		

<p>1.</p>	<p>003844448 in Class 07</p> <p>European Union Intellectual Property Office (EUIPO)</p>	<p>04.06.2017</p>	
<p>2.</p>	<p>001929720-0001 in Class 09</p> <p>United Kingdom</p>	<p>10.10.2011</p>	
<p>3.</p>	<p>002758136 in Class 09</p> <p>European Union Intellectual Property Office (EUIPO)</p>	<p>28.08.2015</p>	
<p>4.</p>	<p>002304923-0001 in Class 09</p> <p>European Union Intellectual Property Office (EUIPO)</p>	<p>09.09.2013</p>	

5.	187691 in Class 09 India	31.12.2001	
6.	241607 in Class 09 India	20.12.2011	

S.No	Registration No. /	Date of Registration	Representations
	Country		

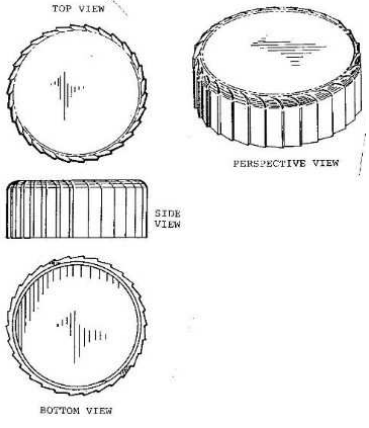
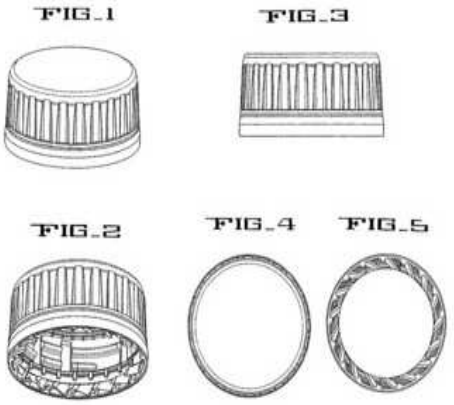
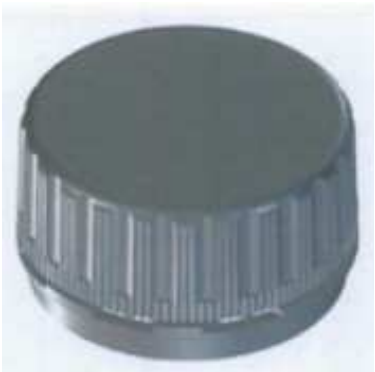
<p>1.</p>	<p>26266 in Class 09</p> <p>New Zealand</p>	<p>28.04.1994</p>	 <p>TOP VIEW</p> <p>PERSPECTIVE VIEW</p> <p>SIDE VIEW</p> <p>BOTTOM VIEW</p>
<p>2.</p>	<p>D578889 in Class 09</p> <p>U.S.A</p>	<p>12.01.2007</p>	 <p>FIG. 1</p> <p>FIG. 3</p> <p>FIG. 2</p> <p>FIG. 4</p> <p>FIG. 5</p>
<p>3.</p>	<p>220287 in Class 09</p> <p>India</p>	<p>17.12.2009</p>	

4.	222366 in Class 09 India	09.04.2009	
----	---------------------------------	------------	---

S.No	Registration No. /	Date of Registration	Country	Representations
1.	US20110174759A1	21.07.2011	U.S.A	

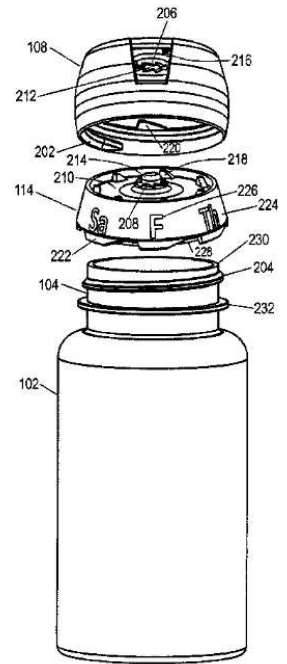
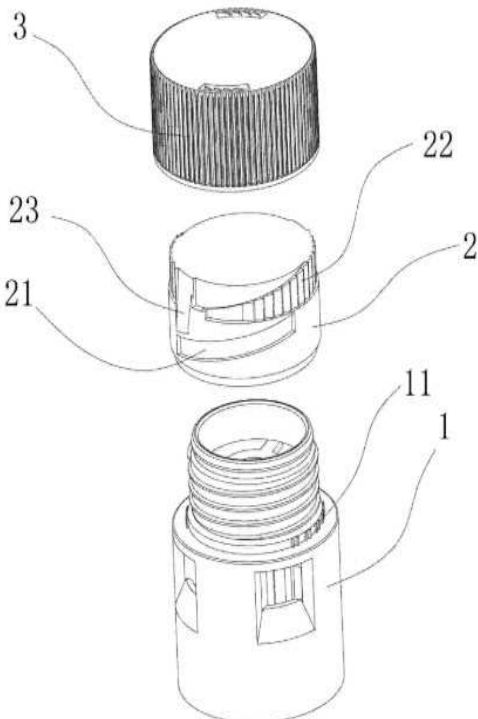
<p>2.</p>	<p>US2017202748A1</p> <p>U.S.A</p>	<p>20.07.2017</p>	
<p>3.</p>	<p>CN203111700U</p> <p>China</p>	<p>07.08.2013</p>	

40. Mr. Kamat submitted that the Plaintiff had not addressed any of the material in either of the two Compilations of Documents on the basis that prior publication must be of an identical design. He submitted that not only is this formulation of the Plaintiff in law fundamentally incorrect but also fatal to the Plaintiff in the case because there is absolutely no answer given by the Plaintiff with respect to all the aforesaid material.

41. Mr. Kamat further submitted that Section 19(1) (b) contemplates that the suit design would stand disentitled from protection if there was prior publication of the design in India or in any other country. The Defendant has undertaken a search of the internet/design registries/patent registries/market to clearly show that the Plaintiff's suit design, as also the features thereof such as shape of the bottles, ridges on the cap and overall configuration are fully pre-empted and vitiated by prior publication in India and other countries. Mr. Kamat submitted that the material produced by the Defendant clearly shows that the bottle with similar shape as also caps with similar shapes has been prior published much before the Plaintiff adopted them. He submitted that, in these circumstances, the Plaintiff cannot claim a monopoly and the Plaintiff's design is hit by Section 19(1)(b) of the Designs Act.

42. Further, Mr. Kamat submitted that the Plaintiffs solitary contention with respect to the second Compilation of Documents filed by the Plaintiff was that Section 19(1)(b) only admits of “identical” prior publication and not of “similar” design which may be prior. He submitted that this contention is entirely contrary to clear, settled law and, in this context, referred to the decisions in **Atomberg Technologies Private Limited** (supra), in **Philips Lighting Holding B. V. vs. Jai Prakash Agarwal and Anr**¹⁰ and **TTK Prestige Limited** (supra).

43. Mr. Kamat submitted that, for all the aforesaid reasons, the suit design is clearly hit by Section 19(1)(b) of the Act. Further, in the context of this defence, Mr. Kamat referred to paragraph 27 of the Plaintiff and submitted that, in paragraph 27 of the Plaintiff, only a reference had been made by the Plaintiff to the Patent Application filed by it. He submitted that the Plaintiff had not placed this Patent Application on record and the Defendant placed this Patent Application on record. He submitted that the same shows that the Plaintiff’s container was disclosed prior to the making of the Design Application. The Patent Application was made on 28th September

10 2022 SCC Online Del 1923

2018 whereas the Application for registration of the design was made on 5th October 2018.

44. Mr. Kamat submitted that, while the Plaintiff has sought to contend that the disclosure made by the Plaintiff in the Patent Application was confidential and therefore saved by the provisions of the Patent Act, 1970 (“the Patent Act”), there is no pleading in the Plaint to suggest that such a disclosure was confidential, and the Plaintiff has merely contended that the Patent Application as a whole was irrelevant for adjudication of the matter.

45. At this ad-interim stage, I am not going into the question as to whether, for the purposes of Section 19(1) (b) of the Designs Act, the prior art published has to be similar or identical to the Plaintiff’s design as, in my view, the prior art and prior publications produced by the Defendant when seen as a whole, are neither deceptively similar nor identical to the Plaintiff’s design. They are substantially different from the Plaintiff’s design as applied to the Plaintiff’s container.

46. The Defendant has sought to compare the caps of other products, or only the body of the bottle, without cap, in isolation, with the Plaintiff’s container. Such a comparison cannot be made in isolation, and, in any event such comparison with the Plaintiffs

container, which is a bottle along with a cap and seal as a single unit, does not reveal any similarity. It is well settled that it is not permissible to break down an article into parts/element/integers and to compare individual parts with parts of the suit container. The article must be viewed as a whole. Mosaicing (i.e., breaking down into pieces from different articles and comparing them with the suit design) is not permissible. The Defendant has sought to dissect the Plaintiff's container into parts and has sought to compare individual elements and features of the Plaintiff's container with other designs, patents and products, which is not permissible. The Plaintiff's design has to be looked as a whole and cannot be segregated, dissected into separate integers. The test of "appeal to the eye" has to be considered for the design as a whole. This is laid down in paragraph 37 of the decision of this Court in **Cello** (supra) which reads as under:-

"37. But what really fails Mr. Tolia's cause is the observation at page 243 of this very report at placetum 10 that the design must be *taken as a whole*. In that case, the House of Lords may have found neither novelty nor originality but I do not think it is at all legitimate for Mr. Tolia to expand this to suggest that the various integers in the bottle be segregated and each integer separately tested for novelty and originality. That is not even Cello's case. For a given bottle for, say, the manufacture of perfumes, fragrances or specialized liquor products, it is entirely conceivable that the bottle would take a completely unique shape, a never-seen-before combination of shape, configuration and ornamentation."

47. Further, the Plaintiff's registered design is not a combination of known designs as is sought to be alleged by the Defendant. In any

event, it is not a requirement of the law in infringement in relation to a design that every single aspect must be entirely newly concocted and unknown to the history of mankind. If that were so, no new or original design would exist at all. It is a general rule that mosaicing of prior art, i.e., combining selected features from different prior art publications, is not permissible when assessing whether a design is novel. Conversely, mosaicing is also no defence to a charge of infringement of a registered design. Mosaicing contemplates taking known integers or combinations and simply re arranging them. In this context paragraph 28 of the judgement in **Cello** (supra) is relevant and reads as under:-

“28. I must reject too Mr. Tolia's argument of mosaicing. I believe it to be misapplied to this case. It is not a requirement of the law in infringement or passing off in relation to a design that every single aspect must be entirely newly concocted and unknown to the history of mankind. If that were so, we should never see any new or original design at all. It is a general rule that “mosaicing” of prior art, i.e., combining selected features in different prior art publications, is not permissible when assessing whether an invention is new. Conversely, mosaicing is also no defence to a charge of infringement of a registered design. Mosaicing contemplates taking known integers or combinations and simply re-arranging them. In a situation like ours, it might for example apply if Cello laid claim to a very similar bottle with a similar shape, configuration and ornamentation but merely repositioned the ornamentation by setting it horizontally rather than vertically and doing not much else besides. That is not the case here.”

48. Further, the term design as defined under the Designs Act means the design of an article capable of being made and sold separately. The phrase “combination of know designs” as stipulated in

Section 4(c) of the Designs Act only prohibits a combination of known articles and not parts thereof. The same does not extend to a part of known articles. Hence, even if some integers of a design were a part of a previously known article, its use in the specified manner to yield a novel article is not forbidden and the article taken as a whole would constitute a new design. This is laid down in paragraph 49 of the decision of this Court in **Selvel Industries and Anr.** (supra) which reads as under:-

“49. Whirlpool was carried in appeal. The Division Bench also rejected the argument raised on behalf of Videocon that Whirlpool's design was merely a combination of known designs and, therefore, lacked originality. After looking at the definitions of article and design in the Designs Act, 2000, the Division Bench concluded that it is the article by itself that must have its stand-alone identity. ‘Design’, in this context, means the design of a article capable of being made and sold separately. The phrase ‘combination of known designs’ in the prohibitory Section 4(c) obviously means a combination of known articles. It is this that is prohibited; the interdiction does not extend to parts of known articles. Therefore, even if the wave-form integer was part of a previously known article, its use in the specified manner to yield a novel article is not forbidden.”

49. Further, as far as the Patent Application of the Plaintiff is concerned, the filing of the said Patent Application prior to Plaintiff's Design Application is of no consequence and does not constitute prior publication. The Patent Application was made on 20th September 2018. The Design Application was made on 5th October 2018. The Patent Application was published only on 3rd April 2020, much after the Design Application was made. In these circumstances, as on the

date of the Design Application, the Patent Application was confidential and not published. In this context, reference can be made to Section 11A of the Patents Act, 1970 (“the Patents Act”). Subsection (1) of the Section 11 (A) provides that no application for patent shall ordinarily be open to the public for such period as may be prescribed. Rule 24 of the Patents Rules, 2000 prescribes this period as eighteen months. Rule 24 of the Patent Rules, 2003 thus makes it clear that the Plaintiff’s container design, even assuming that the same was disclosed in the Patent Application, was confidential and could not be and was not made known to the public till about 3rd April 2020. Thus, the Patent Application of the Plaintiff cannot constitute prior publication. Further, Section 16 of the Designs Act especially protects any disclosure made in confidentiality (like under Section 11(A) of the Patents Act read with Rule 24 of the Patents Rules) and such confidential disclosure does not invalidate a design registration.

50. Further, in any event, there is no question of prior publication of the Plaintiff’s container in the Patent Application as the Patent Application does not display the look and feel of the container as it would appeal to the eye i.e., as visually seen by the eye and as represented in the design registration.

51. For all these reasons, I am unable to accept the submission of the Defendant that the suit design is disentitled from protection under Section 19 (1)(b) of the Act because it has been published in India or any other country prior to the date of registration.

52. The next submission of Mr. Kamat was that the suit design is disentitled from protection under Section 19(1) (c) of the Designs Act because it is not a new or original design and is at best a mere trade variant of an existing/known design which does not qualify for protection under the Designs Act. In this context, Mr. Kamat submitted that the Plaintiff's design is not new or novel or original. He submitted that the material produced by the Defendant of a date prior to the Suit design's priority date clearly showed that the suit design is neither new or original and is at best a mere trade variant of the existing designs.

53. In this context, Mr. Kamat submitted that it is settled law that even if the prior art produced is similar enough and not necessarily identical to the suit design, it would destroy the novelty/originality claims of the Plaintiffs suit design.

54. Mr. Kamat submitted that the Courts have held that minor tweaks and variations are wholly insufficient to take a design far enough from a known/prior design so as to qualify as new or novel

original and that the difference must be substantial/significant. He submitted that, that being the case, the Plaintiff's design and Plaintiff's container is nothing but a trade variant and is independently hit by Section 19(1)(c) of the Designs Act, read with Section 4(c) of the Designs Act. In support of this submission, Mr. Kamat placed reliance on the decision in the case of **Philips Lighting Holding B. V. (supra)**

55. Mr. Kamat submitted that it is absolutely clear that the trivial variations and usage of buzzwords of the kind used by the Plaintiff would not make the Plaintiff's design new or original within the meaning of the Designs Act. At best, such variations are to be assumed to be trivial and therefore the Plaintiff's design and/or product be treated as a mere trade variant. He submitted that this aspect was highlighted in paragraphs 25 to 27 of the decision in the case of **Atomberg Technologies Private Limited (supra)**.

56. Mr. Kamat also relied on paragraph 32 to 50 of the decision in the case of **Jayson Industries (supra)** where the Court observed in the context of certain features of the suit design therein, as applied to plastic everyday houseware, that, as far as the rim was concerned, no doubt, there may be minor variations regarding their shape, number, the extent of the protrusion from the rim and such other minor

features. However, the Plaintiff therein had not be able to convince the Court that these changes made any substantial difference. Mr. Kamat also referred to paragraph 49 of the said decision, wherein the Court upheld Defendant's defence under Section 19(1) (c) by disregarding minor variations to find that the suit design was a mere trade variant and therefore was not neither novel nor original.

57. Before giving my findings on this defence of the Defendant, it would be useful to refer to the decision relied upon by Mr. Kamat in that regard.

58. Paragraphs 59 to 62 of the decision in the case of **Phillips** (supra) reads as under :

“59. In my view, however, the above distinctions are not substantial enough to hold that the plaintiff's design is ‘new’ or ‘original’. A Coordinate Bench of this Court in its judgment in Steelbird Hi-Tech India Ltd. (supra), considered the test to be adopted by the Court while judging whether the design claimed by the plaintiff is new or original or a trade variant to an old design. This Court held as under:—

“16. It was expressed by Buckley L.J. on the question of quantum of novelty in Simmons v. Mathieson & Cold, (1911) 28 R.P.C. 486 in these words:

“In order to render valid the registration of a Design under the Patents and Designs Act, 1907, there must be novelty and originality, it must be a new or original design. To my mind, that means that there must be a mental conception expressed in a physical form which has not existed before, but has originated in the constructive brain of its proprietor and that must not be in a trivial or infinitesimal degree, but in some substantial degree.”

17. In Phillips v. Barbro Rubber Company (1920) 37 R.P.C. 233, Lord Moulton observed that while question of the meaning of design and of the

fact of its infringement are matters to be judged by the eye, it is necessary with regard to the question of infringement, and still more with regard to the question of novelty or originality, that the eye should be that of an instructed person, i.e. that he should know what was common trade knowledge and usage in the class of articles to which the design applies. The introduction of ordinary trade variants into an old design cannot make it new or original. He went on to give the example saying, if it is common practice to have or not to have, spikes in the soles of running shoes, any man does not make a new and original designs out of an old type of running shoes by putting spikes into the soles. The working world, as well as the trade world, is entitled at its will to take, in all cases, its choice of ordinary trade variants for use in particular instance, and no patent and no registration of a design can prevent an ordinary workman from using or not using trade knowledge of this kind. It was emphasized that it is the duty of the Court to take special care that no design is to be counted as "new and original design" unless it is distinguished from that previously existed by something essentially new or original which is different from ordinary trade variants which have long been common matters of taste workman who made a coat (of ordinary cut) for a customer should be left in tender whether putting braid on the edges of the coat in the ordinary way so common a few years ago, or increasing the number of buttons or the like, would expose him for the prescribed years to an action for having infringed a registered design. On final analysis, it was emphasized that the use of the words "new or original" in the statute is intended to prevent this and that the introduction or substitution of ordinary trade variants in a design is not only insufficient to make the design "new or original" but that it did not even contribute to give it a new or original character. If it is not new or original without them, the presence of them cannot render it so.

18. The question before me for consideration is whether the plaintiffs' design when registered on 1st December, 2011 was new or original or different from what has been done before. As per certificate of registration produced alongwith plaint, the same does not show any light except the novelty is claimed in all views for the whole shape, configuration and surface pattern of the Helmet. 'Original' means that the design originating from the author.

19. Drawing a distinction between 'new' and 'original' Buckley L.J. said in *Dover Ltd. v. Nurnberger Celluloidwaren Fabric Gehruder Wolff*,

(27 R.P.C. 498) that 'new' is referred to a case where the shape or pattern was wholly new in itself and on the other hand 'original' to the case where it was old but new in its application to the particular subject matter. The word 'original', according to the learned Judge "contemplates that the person has originated something, that by the exercise of intellectual activity he has started an idea which had not occurred to anyone before, that a particular pattern or shape or ornament may be rendered applicable to the particular article to which he suggests that it shall be applied".

20. It is rightly held in the cases decided that in the matter of novelty the eye is to be the ultimate test and the determination has to be on the normal ocular impression. In order to know its newness or originality it is necessary that a design identical with or even materially similar to the relevant design should not have been published or registered previously. A slight trivial or infinitesimal variation, from a pre-existing design will not qualify it for registration. Taking into account the nature of the article involved, the change introduced should be substantial. It is not necessary to justify registration that the whole of the design should be new, the newness may be confined to only a part of it but that part must be a significant one and it should be potent enough to impart to the whole design a distinct identity, unless registration is sought for the said part alone.

21. It was laid down by Lord Moulton in *Phillips v. Harbro Rubber Company* (37 R.P.C. 233) that it is the duty of the Court to take special cast that no design shall be counted new or original unless it is distinct from what previously existed by something essentially new or original which is different from ordinary trade variants which may have long been common matters of taste or choice in the trade. It is well established that a registration cannot be deemed effective unless the design or configuration sought to be protected is new, or original and not of a pre-existing common type. (*Ram Sahai v. Angnoo*, AIR 1922 All 496, *Bahkhshi v. Ghulam Mohammad*, AIR 1934 Lah 709 and *The Pilot Pen Co. (India) Private Ltd., Madras v. The Gujarat Industries Private Ltd.*, AIR 1967 Mad 215). Vide *In the matter of Wingate's Registered Design No. 768.611* (52 R.P.C. 126) it was observed that what a substantial difference is, is a question upon which no general principle can be laid down at all; it must depend on the particular facts in each case. In one case a quite small variation in the details of a

design may be enough to make the design something quite different from an existing design. On the other hand, there are cases even where quite large alterations in detail leave two designs for all practical purposes the same. The Court has to consider and look at the design in question with an instructed eye and say whether there is or is not such a substantial difference between that which had been published previously and the registered design as to entitle the proprietor of the registered design to say that at the date of registration that was a new or original design and therefore properly registered.

22. Thus, the design must be held to be valid if the statement of novelty is correctly construed in the narrow sense. However, in other type of cases like the case reported in Neggretti and Zambra v. W.F. Stanley & Co., Ltd. (42 R.P.C. 358), the case was concerned with the design of a thermometer. The Court deciding the action noticed the plaintiffs had produced a useful article of commerce for a particular purpose, which, from its smallness and neatness, was readily distinguishable from the larger thermometers which had gone before; but that was found to be wholly immaterial. "The fact that the plaintiffs have hit upon a useful shaped and useful sized thermometer for the particular purpose in hand", it was found that there is no reason in law why the defendants should not even copy such features of that Design which were common in the trade, nor is it any reason why they should not add to such Design any ordinary trade improvement or trade variant which is obvious as soon as the particular use to which the article is intended to be put is appreciated."

60. Therefore, the test to determine if the design is 'new' or 'original' inter-alia is to determine and exclude ordinary trade variants into an old design. A design identical with or even materially similar to the relevant design should not been published or registered previously. A slight trivial or infinitesimal variation from the pre-existing design shall disqualify the relevant design for registration. The change introduced should be substantial. A balance has to be struck so that novelty and originality may receive the statutory recognition and interest of trade and right of those engaged therein to share common knowledge is also protected. Mere trade variants of what is already in existence or what is common to the trade is not capable of being registered.

61. Applying the above test to the facts of the present case, it prima facie appears that the design of the plaintiff is merely a trade variant of an already-existing registered design(s) cited by the defendant in CS (COMM) 46 of 2019 and as referred hereinabove. The earlier

registered designs are of a tube light on a holder. Though the plaintiff calls its lighting source as a bulb, it is shaped like a small tube light. The learned counsel for the defendant in CS(COMM) 76 of 2019 had asserted that such tube lights are common in trade. The so-called bulb of the plaintiff is attached to a holder by a 'swivel mechanism', which even according to the plaintiff's own case is more functional in nature. Therefore, prima facie it appears that the plaintiff's registered design is a trade variant of an already existing registered design and was not capable of being registered.

62. The submission of the learned counsel for the plaintiff that the registered designs cited by the defendants are for Class 26-05 whereas the plaintiff's design is registered in Class 26-04 and therefore, not relevant, and cannot be accepted. Class 26 is for 'Lighting apparatus'. Class 26-04 is a sub-class and is for 'Luminous sources, electrical or not'. The Note(s) appended to Class 26-04 clarifies that the sub-class is 'including bulbs for electrical lamps, luminous plaques and tubes, and candles.' Class 26-05 is for 'Lamps, Standard Lamps, Chandeliers, wall and Ceiling fixtures, lampshades, reflectors, photographic and cinematographic projector lamps.' Section 6 of the Act provides that a design may be registered in respect of any or all of the articles comprised in a prescribed 'class of articles.' Any question arising as to the class within which any article falls shall be determined by the Controller, whose decision shall be final. Sub-section (3) of Section 6 of the Act further provides that where a design has been registered in respect of any article comprised in a class of article, the application of the proprietor of the design to register it in respect of some one or more other articles comprised in that class of articles shall not be refused, nor shall the registration thereof be invalidated on the ground of it being so previously registered for the other article or being previously published in India or in any other country by reason of its application to that other article. The proviso further states that the subsequent registration shall not extend the period of copyright in the design beyond that arising from previous registration. Therefore, once a design is registered for one of the articles in a class of articles, the proprietor can claim a right even for other articles in the same class of articles. Equally, someone else cannot claim to become proprietor of the design by seeking registration thereof in another sub-class of the same class of articles. It has not been shown that the classification of the earlier registered articles or that of the plaintiff was determined by the Controller upon contest and therefore, finality is attached to it."

(Emphasis supplied)

59. Paragraphs 25 to 27 of the decision in **Atomberg Technologies**

Private Limited (supra) read as under:-

“25. This aspect becomes crucial for the purposes of the present application, when the said documents are read in conjunction with the pleading of the plaintiff in paragraph 8 of the plaint. It is specifically pleaded in paragraph 8 of the plaint that the ceiling fan of the plaintiff in question named Atomberg Renesa Ceiling Fan was formerly known as Atomberg Gorilla Renesa Ceiling Fan. The defendant is justified in contending that when such material is appreciated, it leads to the inference that Atomberg Gorilla Renesa Ceiling Fan and Atomberg Renesa Ceiling Fan are interchangeable. Although the plaintiff has tried in its rejoinder affidavit to explain the said aspect of the matter, inter alia, claiming that Atomberg and Gorilla are house-marks of the plaintiff and that with time, the plaintiff gave up the use of the house-mark Gorilla, at this stage, this Court is of the opinion that such an explanation cannot come to the aid of the plaintiff, while deciding the application for interim reliefs. The stated stand taken in paragraph 8 of the plaint read with Exhibits Q, R and S, as also the delivery challans and invoices placed on record, do create an impression that the plaintiff's design was already in public domain and published prior to the date of registration i.e. 8th September, 2018. A perusal of the designs of the fans shown at Exhibits Q, R and S prima facie shows that they are similar to the registered design of the plaintiff. This indicates that the registration of plaintiff's design may itself be hit by Sections 4 (b) and 19(b) of the Designs Act. When this Court is exercising discretion for grant of interim reliefs, the plaintiff not having disclosed the documents at Exhibits Q, R and S alongwith the delivery challans and invoices filed with the reply affidavit, is a crucial aspect of the matter and it indicates that the plaintiff is not entitled for grant of such interim reliefs.

26. Apart from this, this Court has considered the rival contentions on the aspect of novelty and originality claimed by the plaintiff in its design of ceiling fan. It was emphasized on behalf of the plaintiff that even if the pictures of ceiling fans shown at Exhibits Q, R and S, were to be taken into consideration, there was a marked difference in the shape of the blades of the fan insofar as the registered design is concerned and that therefore, the novelty and originality in the registered design is clearly made out. It was emphasized that when the registered design is compared with other designs of ceiling fans on which the defendant has relied, it becomes even more obvious that the registered design of the plaintiff was indeed new and original. In this regard, much emphasis was placed on the detailed table of comparison brought to the notice of this Court, showing the registered design of the plaintiff's ceiling fan being compared to other ceiling fans, as also the earlier ceiling fans of the plaintiff itself.

27. This Court is of the opinion that although the plaintiff may claim that its registered design is considerably different, new,

unique and original as compared to the designs of ceiling fans in the public domain, but, the design of the ceiling fan depicted by the plaintiff itself at Exhibits Q, R and S in the public domain is prima facie found to be almost similar to the registered design. The difference, if at all, is slight and trivial and therefore, the plaintiff has failed to make out a strong prima facie case about novelty and originality of its registered design. In that sense, the defendant is justified in claiming that the plaintiff cannot rely upon a mere trade variant to seek orders of interim injunction against third parties. Reliance placed on the decision of the Delhi High Court in the case of Philips Lighting Holding B.V. v. Jai Prakash Agarwal (supra) is appropriate.

(Emphasis supplied)

60. Paragraphs 47, 48 and 49 of the decision in **Jayson Industries**

(supra) read as under;-

“47. If the differences between prior art and the suit design are merely trade variants, the suit design cannot aspire either to novelty or to originality. On what is a "trade variant", this Court has consistently been following the principles laid down in **Phillips v. Harbro Rubber Co.**, which was thus distilled by a Division Bench of this Court in **B. Chawla**:

“In **Phillips v. Harbro Rubber Company**, Lord Moulton observed that while question of the meaning of design and of the fact of its infringement are matters to be judged by the eye, it is necessary with regard to the question of infringement, and still more with regard to the question of novelty or originality, that the eye should be that of an instructed person, i.e. that he should know that was common trade knowledge and usage in the class of articles to which the design applies. The introduction of ordinary trade variants into an old design cannot make it new or original, He went on to give the example saying, if it is common practice to have) or not to have, spikes in the soles of running shoes any man does not make a new and original designs out of an old type of running shoes by putting spikes into the sales. The working world, as well as the trade world, is entitled at its will to take, in all cases, its choice of ordinary trade variants for use in particular instance, and no patent and no registration of a design can prevent an ordinary workman from using or not using trade knowledge of this kind. It was emphasized that it is the duty of the court to take special care that no design is to be counted a "new and original design" unless it distinguished from that previously existed by something essentially new or original which is different

from ordinary trade variants which have long been common matters of taste workman who made a coat (of ordinary cut) for a customer should be left in tender whether putting braid on the edges of the coat in the ordinary way so common a few years ago, or increasing the number of buttons or the like, would expose him for the prescribed years to an action for having infringed a registered design. On final analysis, it was emphasized that the use of the words "new or original" in the statute is intended to prevent this and that the introduction or substitution of ordinary trade variants in a design is not only insufficient to make the design "new or original" but that it did not even contribute to give it a new or original character. If it is not new or original without them the presence of them cannot render it so."

Applying the law to facts

48. When the aforesaid legal position is applied to the suit designs, vis-a-vis the prior art to which Mr. Sushant Singh has drawn attention, this Court is unable to convince itself that the suit designs can be treated as, prima facie, novel and original vis-a-vis prior art. The only two features of the suit designs, in which novelty and originality are claimed by the plaintiffs, are the vertical ribs along the length of the suit designs and the flanges on the rim. The various prior arts to which Mr. Sushant has alluded clearly indicate that vertical ribs along the length of the bucket/tub/mug in question, from apex to base, as well as extended flanges at the rim of the concerned vessel, are not features which have originated from the plaintiff, but have been in use and application even prior thereto. The vertical ribs in the designs are identical to the vertical ribs in the designs constituting prior art.

Insofar as the flanges on the rim are concerned, no doubt, there may be minor variations regarding their shape, number, the extent of their protrusion from the rim, and other such minor features. The plaintiffs have not been able to convince us these changes make any substantial difference to the flanges. These minor changes, therefore, in my considered opinion, constitute merely trade variants within the meaning of the expression as understood in **Phillips**.

49. The following prior published designs (as applied to specific articles), in my view, make out a credible challenge to the validity of the suit designs:

(i) Bathroom tub as uploaded by Sara China Bona Mould on 18 June 2019:

(ii) Mug, as uploaded by Sara China Bona Mould on 18 June 2019:

(iii) Tub No. BN2103169 invoiced by Bona Mould to Crown Craft, Jaipur on 26 June 2019:

(iv) Mug No. BN2103170 invoiced by Bona Mould to Crown Craft, Jaipur on 26 June 2019:

(v) Bucket from the catalogue of Migeplastics:

(vi) Design 784645 registered in favour of David A. Richardson

(vii) SeMius Durable Practical Solid Geometric Shape Storage Garbage Household Trash Can available on amazon.in since 14 March 2019:

These designs constitute legitimate prior art so as to constitute prior publication within the meaning of Section 4(b) read with 19(d), and 19(b), as well as to divest the suit designs of novelty and originality within the meaning of Section 4(a)/19(c) of the Designs Act.”

61. In my view, the Defendant’s argument that the Plaintiff’s container is a mere trade variant of a known design is not correct. The Defendant has failed to demonstrate that there is any prior design or one very similar to it that precedes the Plaintiff’s design or that the Plaintiff has merely created a trade variant.

62. It is entirely possible to take two old or known integers and combine them in a new way, one which taken as a whole is different, creates a different appeal to the eye and qualifies as a design which is new and original. In this context paragraphs 37 and 42 of **Selvel Industries** (supra) are relevant and read as under:-

“37. But the Defendant does not stop there. It then proceeds to show a number of lids and other containers with some sort of wave or the other to claim that others also have either airtight lids or waves. None of these, in my view, remotely resemble the Plaintiffs’ product. The Defendant’s product does. It is actually

no more complicated than that. For example, the reference to one such allegedly similar product, made by one M.M. Plastoware, turns out to be of very little use. It has a wave that is unlike the one to be found in either the Plaintiffs' or Defendant's products, and in any case its registration seems to be of 27th November 2015, well after the Plaintiffs' products were introduced. I have not understood Dr. Saraf to claim novelty in every kind of wave. What Dr. Saraf claims is that one must have regard to the object as a whole and look to see if there is novelty in the design of the article in its entirety and not proceed to deconstruct the object into constituent elements and then to say that those constituent elements are not novel. It may often happen, and I think both counsel in fairness agree on this as a matter of law, that two previously known components or integers may be combined or applied in such a way so as to result in a completely novel design. Therefore, to suggest that there is no novelty in the shape, that the wave itself is not novel and, therefore, the addition of the wave to the container cannot possibly be novel and is necessarily only a trade variant is not an acceptable argument. What the Defendant must show is that there is such a design, or one very similar to it, that preceded the Plaintiffs' design; that would rob the Plaintiffs' design of the necessary newness and originality.

42. Mr. Khandekar also relies on the decision of another learned Single Judge of the Delhi High Court in *Amit Jain v. Ayurveda Herbal*. In fairness, he does so for a limited purpose, and only to suggest that in assessing novelty, the Court must consider whether there is a similar ornamentation, shape, configuration or pattern, and whether what is claimed to be novel is only a small, trivial or slight variation; or, as Mr. Khandekar puts it, a trade variant. On the strength of this, he submits that the change introduced should be 'substantial'; not necessarily that the whole of the design should be new, for the novelty and originality may be confined to a part of it, but that part must be, in his words, 'significant and potent enough' to impart to the whole design a distinct identity. I believe the proposition is overbroad. I am also unable to agree with the observations in paragraph 32 of the *Amit Jain* decision. These seem to me too broadly stated to admit of ready application to other cases. The paragraph suggests that even new integers must have intrinsic or inherent novelty. This cannot possibly be correct. It is entirely possible to take two old or known integers and combine them in a new way, one that is purely aesthetic and appeals to the eye, by a process contemplated by the statutory definition, and to yet receive a result that qualifies as a design, both entirely new and entirely original. We see many such examples. From lead pencils to match boxes, there is no limit to human imagination or innovation. In any case, the question is academic : there is no 'old' material shown to justify this submission."

63. Whether or not a particular article or its design is a trade variant is based on three factors namely, (i) the nature and size of the article to which the design has to be applied, (ii) the utilitarian nature of the article (iii) if the article's nature or size is such that only minor or small changes may be possible to be made, such minor or small changes may be sufficient/substantial enough to make the design new/novel and unique. A change made in an already available design may be trivial when considered from the standpoint of some articles but may, on the other hand, be substantial in the case of some others. In this context, it would be useful to refer to paragraphs 10 and 11 of the decision of this Court in **Frito-Lay North America Inc.** (supra), which read as under :-

“10. We are at an ad-interim stage, where the parties are yet to file detailed affidavits and make out proper *prima facie* cases. The Plaintiffs' case and the defence advocated by the Defendant have to be seen from that standpoint. Secondly, what is important to note is that in assessing the cases, one has to go by nothing but a general ocular impression; the novelty or otherwise of the product has to be assessed with eye as the ultimate arbiter. Thirdly, it is important to bear in mind the nature of the particular article to which the subject design is applied, and not bare geometry of the shape or design in abstract. A change made in an already available design may be trivial when considered from the standpoint of some articles, but may, on the other hand, be substantial in case of some others.

11. What is at once visible to the eye in the present case is that compared generally to wavy-shaped designs of snacks, particularly potato chips, which have already been published in the country or elsewhere, the shape and configuration of the Plaintiffs' designs, applied to their chips, do *prima facie* indicate a marked distinction. The ridges and crusts in the Plaintiffs' designs do have marked prominence and angularity and, to the bare eye, seem to be distinct from the generally wavy pattern of chips otherwise available in the market. The products, which are already available in public domain and which are relied upon by

the Defendant, mostly come with a design of gentle waves unlike the Plaintiffs' registered designs which have distinctly deep ridges and crusts. The only other designs, which may be termed as substantially similar to, or more or less exact imitation of, the Plaintiffs' designs, are contained in the food products referred to on pages 64 and 70 of the Defendant's compilation, but then these are obviously, in point of time, much after the Plaintiffs' registration and cannot be called previously published or existing designs. One cannot even say generally, from a geometrical stand point, that a gently wavy shape or pattern is not distinct or different from a sharp-edged mountain-ridge shape or pattern. But it would be particularly so in case of potato chips. It may be that in a given case, say, in case of tin roofs, the distinction may not be as significant, but in the case of potato chips, which are small size eatables, these differences cannot be dismissed as insignificant or trivial. By way of a general ocular impression, with eye as the final arbiter, one can indeed recognize a new and original idea in the Plaintiffs' registered designs in the backdrop of wavy designs otherwise available in the market. Having regard to the material produced by the Defendant before this Court, at this stage, this Court cannot come to the conclusion that the Defendant has *prima facie* established that the Plaintiffs' registration of designs is liable to be cancelled. In that case, the Plaintiffs do deserve an ad-interim protection based on their registration.”

64. The submission that the Plaintiff's container is not significantly distinguishable from known designs or a combination of known designs is not tenable. In this regard reference may be made to the paragraph 34 of the decision in **Cello** (supra), which reads as under:-

“34. I am not impressed by Mr. Tolia's argument based on Section 4(1)(c) of the Designs Act 2000 that the Plaintiffs' bottle is not significantly distinguishable from known designs or a combination of known designs. This is not demonstrated in the least. His argument is that since a bottle is a bottle, and is always only a bottle, only an expert that can tell one bottle from the other. I do not think this is remotely true. For some who claim familiarity with bottles - perhaps for reasons unrelated to their design - the differences are evident; many cylindrical liquid containers are instantly recognized as unique and as indicative of their contents. The expertise, usually borne of much experience, in such cases has not so much to do with the design of a bottle as its contents. No “expert” can add much more than that which is obvious to the naked eye.”

65. In my view, the features of the Plaintiff's design taken together or as a whole are not present in any of the prior cited designs. For a design to be a trade variant, this Court would have to come to the conclusion that the unique features of the Plaintiff's design are minor or inconsequential in nature. A bare perusal of the cited designs and Plaintiff's registered design would show that they are infact substantially dissimilar.

66. Further, the differences in the features of the Plaintiff's registered design and the other designs cited can, in my view, not be termed as minor or inconsequential, and given the nature of the product involved, namely a container, the Plaintiff's registered design cannot be termed as a trade variant.

67. Further, the fact that the Plaintiff's registered design is new novel and original is also established by the fact that the Defendant, who has been in the same trade, has not manufactured a container with the same or even remotely same design as that of the Plaintiff's registered design till 30th November 2023.

68. For all the aforesaid reasons, in my view, the submission of the Defendant that the suit design is disentitled from protection under Section 19(c) of the Act because it is not a new and original design

and is a mere trade variant of existing/known design cannot be accepted.

69. The main thrust of the Plaintiff in the ad-interim application was in respect of the infringement of its registered design for which the Plaintiff has sought ad interim reliefs in terms of prayer (a) of the Interim Application. For this reason, I have considered the submissions of the parties only in order to consider whether ad interim reliefs in terms of prayer (a) of the Application are required to be granted or not.

70. For all the aforesaid reasons, the Plaintiff has made out a prima facie case for grant of ad-interim reliefs in terms of prayer (a) of the Interim Application. If the injunction as sought in prayer (a) is not granted, then grave loss, harm and prejudice would be caused to the Plaintiff as the Defendant would then continue to use the impugned container with the design of the Plaintiff. The balance of convenience is also in favour of the Plaintiff and against the Defendant.

71. In the light of the aforesaid discussion, and for the aforesaid reasons, the Plaintiff is entitled to ad interim reliefs in terms of prayer (a) of the Interim Application which reads as under:-

(a) Pending the hearing and final disposal of the suit, the Defendant, its directors, owners, servants, subordinates, representatives, stockists, dealers, agents and all other persons

claiming through or under them or acting on their behalf or under their instructions be restrained by an order an injunction of this Hon;ble Court from pirating or infringing the Plaintiff's right in the registered design bearing no.310662 in any manner and from manufacturing, selling, dealing in, offering to sell any products in the Impugned Container or any other containers or packaging materials or jars or bottles which are or contain or have applied upon it the said registered design owned by the Plaintiff in respect of the Distinctive M-SEAL PV SEAL Container or any fraudulent or obvious imitation thereof;"

(FIRDOSH P. POONIWALLA, J.)

At the request of Mr. Khandekar, the learned Counsel appearing on behalf of the Defendant, the operation of this order is stayed for a period of two weeks from today.

(FIRDOSH P. POONIWALLA, J.)